

## Variable Reluctance Speed Sensor

### E12A

**GREEN LINE**  
INDUSTRIAL SPEED SENSORS

#### Product ID

Type #	Product #	Drawing #
E12A	385Z-05320	113.586 Rev.1

#### General

**Function** The E12A series variable reluctance (VR) speed sensors consist of an iron core, an inductive coil, and a permanent magnet. A ferrous pole wheel passing the sensor face changes the magnetic field strength, resulting in an AC voltage being induced in the coil. The frequency of the output signal is proportional to the speed of the moving target. The amplitude of the signal depends on speed, air gap, geometry of target, magnetic properties of target material, and the electrical load. VR sensors, also known as passive or electromagnetic sensors, do not require an external supply.

#### Technical data

**Coil properties** Inductance @ 1 kHz: 170 mH  $\pm$  10%  
Resistance: 850 Ohm  $\pm$  10%  
Magnet polarity: north pole towards front face  
Pole piece: diameter 2.7 mm

**Polarity** Upon approach of ferrous metal, the signal pin is positive with respect to GND.

**Signal output** The signal frequency is proportional to the target speed.  
The signal amplitude shown in the figure is valid for a load of 100 kOhm, and is affected by air gap, target geometry and material. It is also proportional to the linear speed of the teeth.

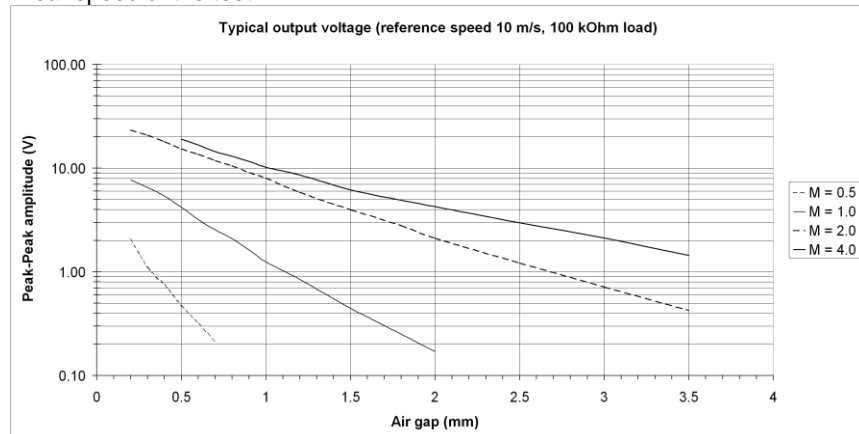

**Frequency range** Up to 20 kHz, lower limit depending on application

**Housing** M12x1, tightening torque: max. 12 Nm

**Connection** Connector: M12x1 thread, 4 pins, black

**Protection** Sensor head: IP68  
Connector: IP67

**Insulation** Housing and electronics galvanically isolated (Test: 500 V, 50 Hz for 1 minute)

**Pole wheel** Prerequisite: Toothed wheel of a ferrous material (e.g. Steel 1.0036).  
Optimal performance with  
Involute gear  
Tooth width > 10 mm  
Side offset < 0.2 mm  
Eccentricity < 0.2 mm

**Air gap between sensor and** Depending on lowest circumferential speed which has to be detected and on

pole wheel	trigger level. See figure.
Electromagnetic compatibility (EMC)	Please contact Jaquet for further details.
Vibration & shock immunity	Jaquet Greenline sensors are approved for rough environments. Please contact Jaquet for further details.
Operating temperature	-40°C...125°C

### Further Information

Safety	All mechanical installations must be carried out by an expert. General safety requirements have to be met.
Installation	<p>The sensor has to be aligned to the pole wheel according to the sensor drawing independent of its rotational orientation. Deviations in positioning may affect the performance and decrease the noise immunity of the sensor. During installation, the smallest possible pole wheel to sensor gap should be set. The gap should however be set to prevent the face of the sensor ever touching the pole wheel. A sensor should be mounted with the middle of the face side over the middle of the pole wheel. Dependent upon the wheel width, a certain degree of axial movement is permissible. However, the middle of the sensor must be at minimum in a distance of 3 mm from the edge of the pole wheel under all operating conditions.</p> <p>A solid and vibration free mounting of the sensor is important. Eventual sensor vibration relative to the pole wheel can induce additional output pulses. The sensors are insensitive to oil, grease etc. and can be installed in arduous conditions.</p>
Maintenance	Product cannot be repaired.
Transport	Product must be handled with care to prevent damage of the front face.
Storage	Product must be stored in dry conditions. The storage temperature corresponds to the operation temperature.
Disposal	Product must be disposed of properly, it must not be disposed as domestic waste.

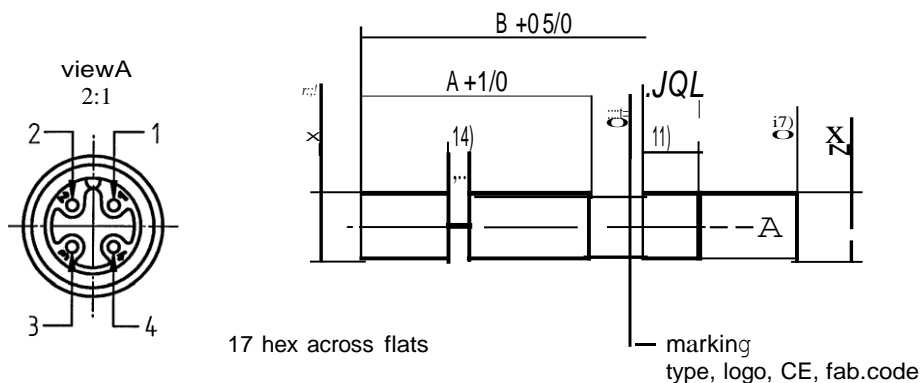

part no.	Jaquet	A	B
385Z-05320	E12A	40	59.7
385Z-05570	EX12A	40	59.7
385Z-05571	EX12A35	89	108.7

connecting diagram:

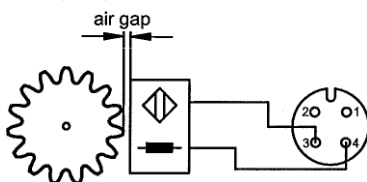

contact configuration:

- 1 not connected
- 2 not connected
- 3 GND
- 4 signal (-)

mates with straight plug M12x1, 4 pins

**EX-CERTIFIED PRODUCT**  
MUST BE APPROVED BY THE AUTHORIZED JAUQUET  
EX-REPRESENTATIVE

FOR TECHNICAL SPECIFICATIONS SEE OPERATING INSTRUGTIONS

dimensions in mm						
part no.	material / remarks			application		
	-/-			nominal size range		
	-/-			allowed toleran[ce]		
	-/-			repl[acem]ent for		
	10.11.06/ebi	aktualisiert im Rahmen der GreenUne Erweiterung		first angle projection	drawn	27.09.2006
	signature	chnge description		-EJS-	approved	3/1, ...0+ / /)
<b>JAG.UET</b> TECHNOLOGY GROUP Thannerstrasse 15 CH-4009 Basel www.jaquet.com					SEale 1:1	drawing no.
				A4	113.586	1